

*Nourison*TM

COLLECTIONS

VOLUME 2 | 2020



OUR HISTORY

As we approach our 40th year of business, we look back on the events and people that have made us the successful company that we are today. The road to forty hasn't always been easy. We are thankful for both the good times and bad as they have strengthened us as a family and an organization.

We also are thankful for YOU, our customers, partners and friends. You have continually challenged us to develop better products and improve our service levels. Nourison would not be the leader we are today if not for your requests, patience and encouragement.

Please enjoy this catalog. It includes our best-selling styles, trend pieces and new introductions. We look forward to another exciting forty years of business together and hope these products help you get 2020 off to a successful start.

Thank you,

-Nourison



LW02 BLUE/IVORY

2020 COLLECTIONS **CONTENTS**

1	AMORE
7	ANKARA GLOBAL
13	CELESTIAL
19	CONTOUR
23	DECO MOD
25	DENMARK SHAG
27	FANTASY
31	FUSION
35	INTERLOCK
37	JAZMINE
41	JEWEL
45	KARMA
49	LAGOS
53	LUSTROUS WEAVE
57	LUXE SHAG
59	MARANA
61	MAXELL
67	NOMAD
71	NOURISON 2020
75	OSLO SHAG
79	RIO VISTA
81	RUSTIC TEXTURES
87	SILKY TEXTURES
91	SOMERSET
101	SYMMETRY
109	VIBRANT
113	WESTON

SIZING TIPS

HOW TO CHOOSE
THE RIGHT RUG SIZE

LIVING ROOM

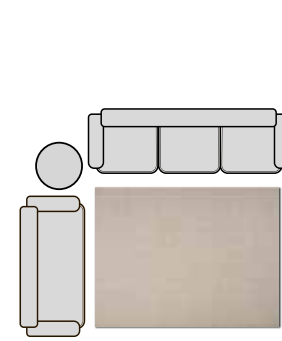

5' x 8' - 6' x 9'

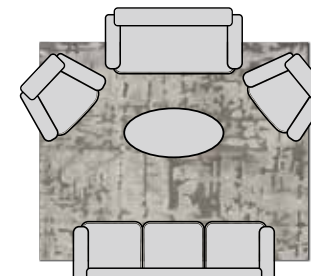

8' x 10' - 9' x 12'

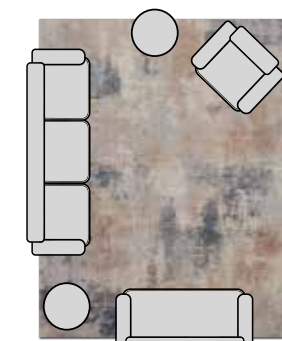

9' x 12' - 10' x 14'

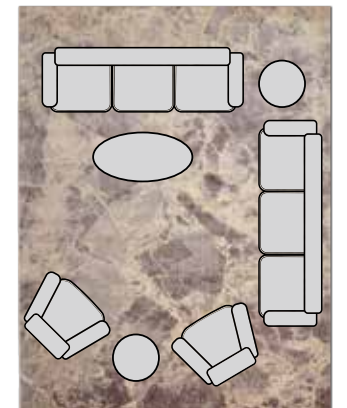

10' x 14' - 12' x 15'

PROVIDING MEASUREMENTS OF THE ROOM AND FURNITURE
ENSURES YOU GET THE RIGHT RUG FOR THE SPACE

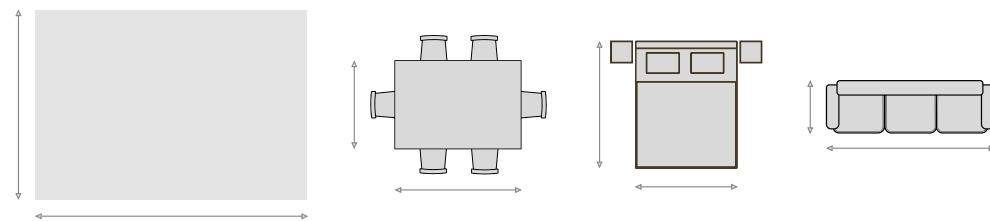

LIVING ROOM TIP

Make sure your rug is sized properly for the furniture and seating area.
The rug should pull each piece together into a single area.

DINING ROOM

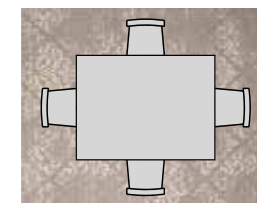

8' x 10'

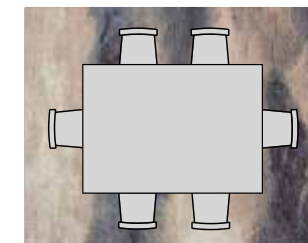

8' x 11' - 9' x 12'

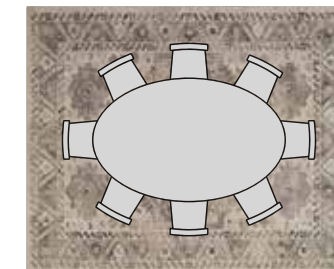

9' x 12' - 10' x 14'

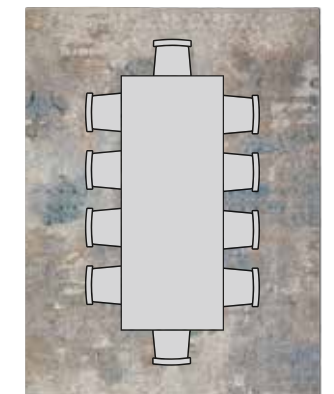

10' x 14' - 12' x 15'

DINING ROOM TIP

Leave 18-24 inches of rug on all sides, so that chairs stay on the rug when
pulled back. Rug should be sized to fit the room, not the table.

BEDROOM TIP

Leave at least 18 inches of rug on either side of the bed. You should be
able to get out of bed and still stand on the rug.

BEDROOM

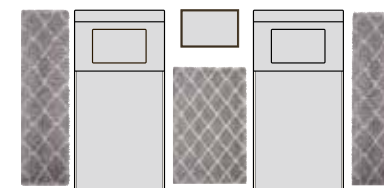

4' x 6' - 5' x 8'
& Runners

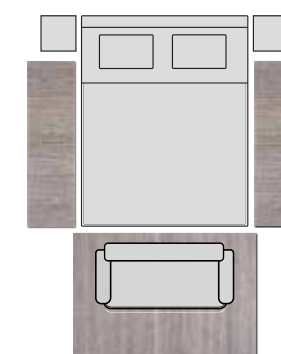

5' x 8' - 6' x 9'
& Runners

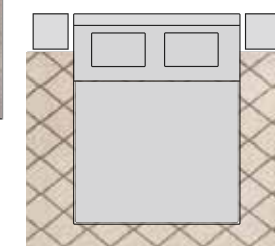

8' x 10' - 9' x 12'

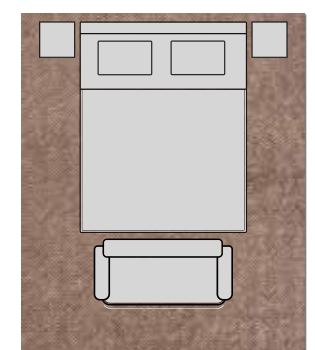

10' x 14' - 12' x 15'

AMORE

COLLECTION



AMORI CREAM

Turn on the charm with this collection of enthralling shag rugs in bold colors. Featuring a beautiful pile that begs to be touched and quality construction that will last for years.

100% POLYPROPYLENE | POWER LOOMED | CONTEMPORARY DESIGN

NOURISON.COM/AMORE

AVAILABLE SIZES

3 ft. 11 in. x 5 ft. 11 in.	1.19m x 1.80m
5 ft. 3 in. x 7 ft. 5 in.	1.60m x 2.26m
7 ft. 10 in. x 10 ft. 10 in.	2.39m x 3.30m



AMORI CREAM

AMORI BLUSH

AMORI STONE

AMORI RED

AMORI BONE

AMORI AQUA

AMORI LIGHT GREY

AMORI SLATE BLUE

AMORI DARK GREY

AMORI INK



AMOR2 CHARCOAL

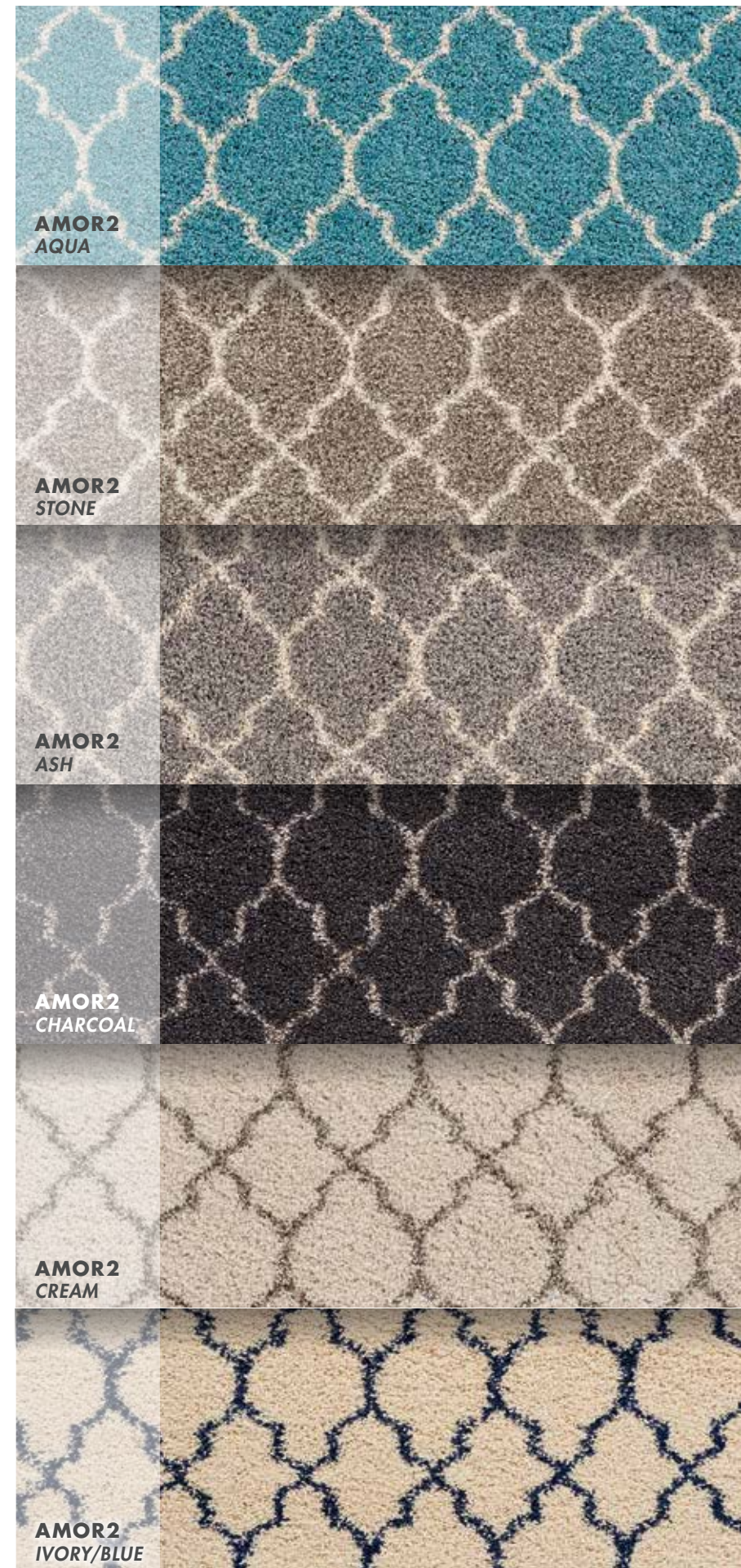

AMOR2
AQUA

AMOR2
STONE

AMOR2
ASH

AMOR2
CHARCOAL

AMOR2
CREAM

AMOR2
IVORY/BLUE

AMOR4 COBBLESTONE



AMOR4 GRANITE



AMOR5 IVORY/SILVER



AMOR5 SILVER/ CHARCOAL



A M O R E

A M O R E



AMOR3 MARBLE/CLOSE UP

AMOR3 MARBLE

AMOR5 IVORY/SILVER

ANKARA GLOBAL

COLLECTION



ANR10 MULTICOLOR

ANR06 IVORY/ORANGE



ANR06 IVORY/BLUE



ANKARA GLOBAL



ANR09 IVORY MULTICOLOR



ANR10 MULTICOLOR

With the look and feel of vintage antiques, the Ankara Global collection brings lavishly ornate Persian and Turkish rug designs together in a richly colorful assortment.

90% POLYPROPYLENE | 10% POLYESTER | POWER LOOMED | TRADITIONAL DESIGN

NOURISON.COM/ANKARA-GLOBAL

AVAILABLE SIZES	2 ft. x 4 ft.	0.61m x 1.22m	5 ft. 3 in. x 7 ft. 6 in.	1.60m x 2.29m
	2 ft. x 6 ft. Runner	0.61m x 1.83m Runner	6 ft. Round	1.83m Round
	2 ft. 4 in. x 8 ft. Runner	0.71m x 2.44m Runner	7 ft. 10 in. x 9 ft. 10 in.	2.39m x 3.00m
	4 ft. Round	1.22m Round	8 ft. 10 in. x 11 ft. 10 in.	2.69m x 3.61m
	4 ft. x 6 ft.	1.22m x 1.83m		



ANR01 MULTICOLOR

ANR02 RED



ANKARA GLOBAL



ANR04 IVORY MULTICOLOR

ANR04 BLUE MULTICOLOR

ANR01 MULTICOLOR

ANR07 BLUE/GREEN



ANR03 BLUE



ANR11 BLUE MULTICOLOR



ANR12 GREY MULTICOLOR



ANKARA GLOBAL

ANKARA GLOBAL

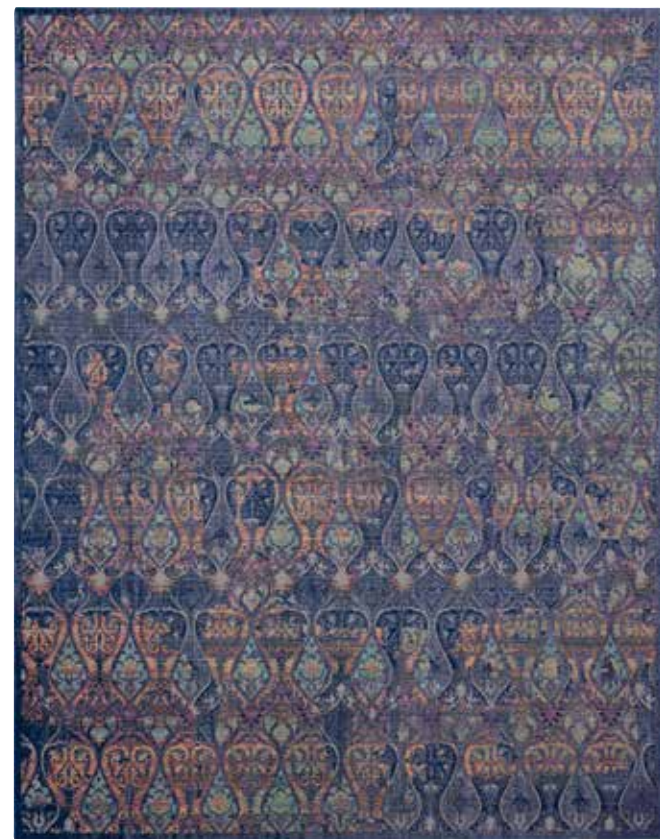

ANR05 MULTICOLOR

ANR08 NAVY MULTICOLOR

ANR13 NAVY MULTICOLOR

ANR14 TEAL MULTICOLOR

CELESTIAL

COLLECTION



CES02 IVORY/PINK

CES02 IVORY/PINK



CES02 IVORY/GREY



CELESTIAL



CES02 SEALIFE



CES02 IVORY/TEAL BLUE

These heavenly area rugs possess a dramatic beauty, with rich, saturated colors that swirl together in unique and vivid designs. Each stunning area rug conveys a sense of movement and energy that verges on divine.

100% POLYPROPYLENE | POWER LOOMED | TRANSITIONAL DESIGN

NOURISON.COM/CELESTIAL

AVAILABLE
SIZES

3 ft. 11 in. x 5 ft. 11 in.	1.19m x 1.80m
5 ft. 3 in. x 7 ft. 3 in.	1.60m x 2.21m
7 ft. 10 in. x 10 ft. 6 in.	2.39m x 3.20m



CES12 IVORY MULTICOLOR



CES09 BLUE/YELLOW



CELESTIAL



CES13 PINK MULTICOLOR



CES14 SUNSET

CES13 PINK MULTICOLOR

CES01 SEAGLASS



CES03 CAYENNE



CES05 BURST



CES07 WAVE

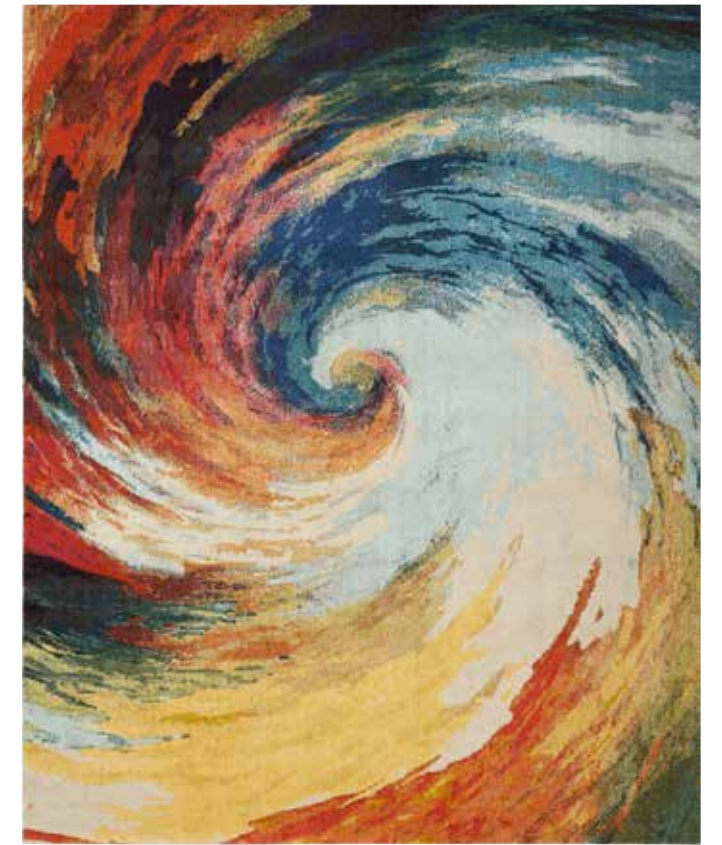

CELESTIAL



CES04 PALETTE



CES08 ATLANTIC

CELESTIAL



CES06 STAINED GLASS

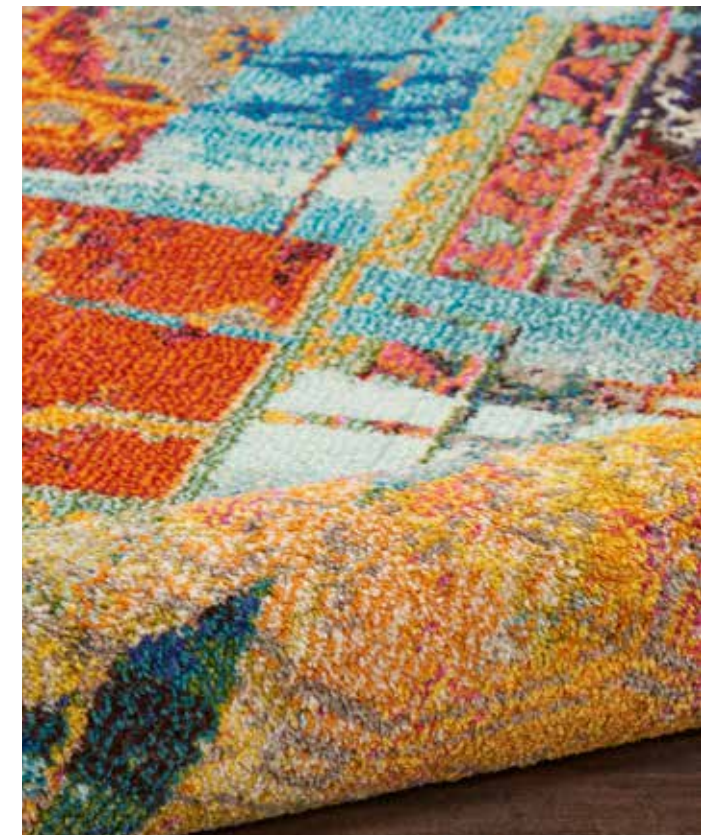

CES06 STAINED GLASS/CLOSE UP

CONTOUR

COLLECTION



CON25 OCEAN SAND

These beautiful, handcrafted rugs feature transitional and contemporary patterns in a rich color palette. Select designs have exquisite detail carved deeply into the dense, cut-and-loop pile for dramatic texture and striking contrast.

100% POLYESTER | HAND TUFTED | CONTEMPORARY DESIGN

NOURISON.COM/CONTOUR

AVAILABLE
SIZES

3 ft. 6 in. x 5 ft. 6 in.	1.07m x 1.68m
5 ft. x 7 ft. 6 in.	1.52m x 2.29m
7 ft. 3 in. x 9 ft. 3 in.	2.21m x 2.82m
8 ft. x 10 ft. 6 in.	2.44m x 3.20m

CON02 MOCHA



CON09 SILVER



CONTOUR



CON23 MULTICOLOR



CON25 OCEAN SAND



CON78 SUNSET



CON15 HARVEST



CONTOUR



CON08 GREY



CON08 NATURAL

CON78 SUNSET

DECO MOD

COLLECTION



DEC01 TAUPE/ IVORY

Features art deco-inspired designs with gorgeous graphic patterns for a striking elegance that is both modern and timeless.

100% POLYESTER | HAND TUFTED | TRANSITIONAL DESIGN

NOURISON.COM/DECO-MOD

AVAILABLE SIZES

2 ft. 3 in. x 7 ft. 6 in. Runner	0.69m x 2.29m Runner
3 ft. 9 in. x 5 ft. 9 in.	1.14m x 1.75m
5 ft. 3 in. x 7 ft. 4 in.	1.60m x 2.23m
8 ft. x 10 ft. 6 in.	2.44m x 3.20m
9 ft. 6 in. x 13 ft.	2.90m x 3.96m



DEC01
TAUPE/
IVORY

DEC01
GREY/
IVORY



DEC03
LIGHT BLUE/
IVORY

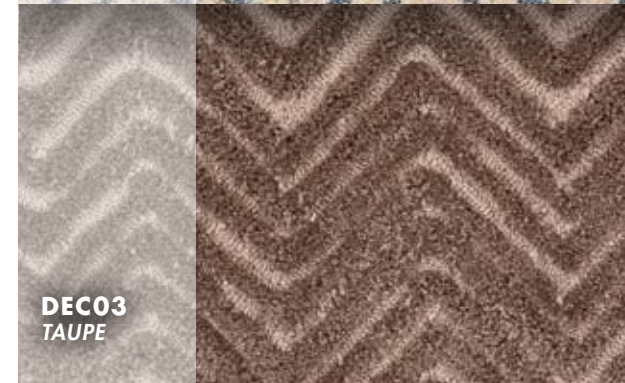

DEC03
TAUPE



DEC03
GREY



DEC02
NAVY/
IVORY

DEC02
BLACK/
BEIGE

DENMARK SHAG

COLLECTION



DNK01 IVORY

Soft neutral tones are adorned with bright, multicolor accents in tribal patterns, with a twisted fringe finish for a warmth and casual comfort that looks great in any décor.

80% POLYPROPYLENE | 20% POLYESTER | POWER LOOMED | CONTEMPORARY DESIGN

NOURISON.COM/DENMARK-SHAG

AVAILABLE SIZES

4 ft. x 6 ft. 3 in.	1.22m x 1.90m
5 ft. 3 in. x 7 ft. 9 in.	1.60m x 2.36m
7 ft. 10 in. x 10 ft. 6 in.	2.39m x 3.20m
9 ft. x 12 ft.	2.74m x 3.66m

DNK01 GREY



DNK03 IVORY



DENMARK SHAG



DNK02 IVORY



DNK04 TAN

FANTASY

COLLECTION



FANTASY



These beautiful transitional rugs are meticulously crafted with high-density, hand-hooked yarns and hand carved for additional texture and dimension.

100% POLYESTER | HAND HOOKED | TRANSITIONAL DESIGN

NOURISON.COM/FANTASY

AVAILABLE SIZES

1 ft. 9 in. x 2 ft. 9 in.	0.53m x 0.84m
2 ft. 3 in. x 8 ft. Runner	0.69m x 2.44m Runner
2 ft. 6 in. x 4 ft.	0.76m x 1.22m
3 ft. 6 in. x 5 ft. 6 in.	1.07m x 1.68m
5 ft. x 7 ft. 6 in.	1.52m x 2.29m
8 ft. x 10 ft. 6 in.	2.44m x 3.20m

FA22 SLATE/CLOSE UP



FA22 SLATE



FA24 BLACK/CLOSE UP



FA24 BLACK



FANTASY



FANTASY



FA26 IVORY

FA26 GREY

FA24 IVORY/AQUA

FA24 SUNSET

FUSION

COLLECTION



FSS12 CREAM/BLUE

The Fusion Collection brings elements from contemporary and traditional rug designs together in rich blues, vibrant pinks, and elegant neutrals.

100% POLYPROPYLENE | POWER LOOMED | TRANSITIONAL DESIGN

NOURISON.COM/FUSION

AVAILABLE SIZES

2 ft. 2 in. x 7 ft. 6 in. Runner	0.66m x 2.29m Runner
4 ft. x 6 ft.	1.22m x 1.83m
5 ft. 3 in. x 7 ft. 3 in.	1.60m x 2.21m
7 ft. 10 in. x 10 ft. 6 in.	2.39m x 3.20m
9 ft. 6 in. x 13 ft.	2.90m x 3.96m

FSS10 CREAM MULTICOLOR



FSS10 GREY



FUSION



FSS11 CREAM



FSS11 CREAM/GREY

FSS13 CREAM/BLUE



FSS13 NAVY/PINK



FSS16 BEIGE/GREY



FSS16 CREAM/GREY



FUSION

FUSION



FSS15 CREAM/GREY

FSS15 NAVY/PINK

FSS17 BLUE MULTICOLOR

FSS17 CREAM MULTICOLOR

INTERLOCK

COLLECTION



ITL01 MULTICOLOR

Hand tufted with a fabulous loop pile for a superb softness and marvelous durability, these stunning rugs feature a unique space-dyeing technique for dramatic depth and dimension that are destined to capture everyone's attention.

100% WOOL | HAND TUFTED | CONTEMPORARY DESIGN

NOURISON.COM/INTERLOCK

AVAILABLE SIZES

2 ft. 3 in. x 7 ft. 6 in. Runner	0.69m x 2.29m Runner
3 ft. 9 in. x 5 ft. 9 in.	1.14m x 1.75m
5 ft. x 7 ft. 6 in.	1.52m x 2.29m
8 ft. x 10 ft. 6 in.	2.44m x 3.20m

ITL01 HEATHER



ITL01 CHARCOAL



INTERLOCK



ITL01 DENIM



ITL01 MARINE

JAZMINE

COLLECTION



JAZMINE



An assortment of corner-and-medallion designs and all-over patterns covered with traditional florals and vase motifs, these traditional Oushak-inspired rugs exude an air of regal elegance and grace.

100% WOOL | HAND TUFTED | TRADITIONAL DESIGN

NOURISON.COM/JAZMINE

AVAILABLE SIZES

2 ft. 3 in. x 8 ft. Runner	0.69m x 2.44m Runner
2 ft. 3 in. x 10 ft. Runner	0.69m x 3.05m Runner
5 ft. 3 in. x 7 ft. 5 in.	1.60m x 2.26m
7 ft. 9 in. x 9 ft. 9 in.	2.36m x 2.97m
8 ft. 6 in. x 11 ft. 6 in.	2.59m x 3.51m



JAZ03 IVORY/BLUE

JAZ02 BLUE



JAZ02 SEAFOAM



JAZMINE



JAZ03 IVORY/BLUE



JAZ03 GREY

JEWEL

COLLECTION



JEL01 EMBER/RED

Sleek, low-pile construction creates a subtle sheen across center medallions, all-over floral patterns, and intricate figures from the world's foremost rug-weaving cultures.

50% POLYPROPYLENE | 50% POLYESTER | POWER LOOMED | TRADITIONAL DESIGN

NOURISON.COM/JEWEL

AVAILABLE SIZES

2 ft. 3 in. x 8 ft. Runner	0.69m x 2.44m Runner
4 ft. x 6 ft.	1.22m x 1.83m
5 ft. 3 in. x 7 ft. 5 in.	1.60m x 2.26m
7 ft. 10 in. x 9 ft. 10 in.	2.39m x 3.00m
9 ft. x 12 ft.	2.74m x 3.66m

JEL01 RED



JEL01 EMBER/RED



JEWEL



JEL01 JADE



JEL01 CREAM/RED

JEL02 CREAM/RED



JEL02 BRICK



JEL04 RED



JEL04 DENIM



JEWEL



JEWEL



JEL03 BLUE/RED

JEL03 BRICK

JEL04 RED

KARMA

COLLECTION



KRM01 LATTE

With its intriguing array of radiant tribal patterns revealed in artfully gradated color palettes, this wonderful collection is warm, inviting and infinitely exciting.

84% POLYPROPYLENE | 16% POLYESTER | POWER LOOMED | TRANSITIONAL DESIGN
NOURISON.COM/KARMA

AVAILABLE SIZES

2 ft. 2 in. x 7 ft. 6 in. Runner	0.66m x 2.29m Runner
3 ft. 9 in. x 5 ft. 9 in.	1.14m x 1.75m
5 ft. 3 in. x 7 ft. 4 in.	1.60m x 2.23m
7 ft. 10 in. x 10 ft. 6 in.	2.39m x 3.20m
9 ft. 3 in. x 12 ft. 9 in.	2.82m x 3.89m

KRM01 LATTE



KRM01 ASH



KARMA



KRM01 BLUE



KRM01 RED



KRM07 IVORY/LIGHT BLUE

KRM02 BEIGE



KRM04 BLUE



K A R M A



KRM05 IVORY/BLUE



KRM07 IVORY/LIGHT BLUE

LAGOS

COLLECTION



LAG01 BLUE

LAG01 CREAM



LAGOS



LAG02 BRICK

LAG05 MULTICOLOR

With its alluring array of traditional designs infused with a soft, glossy sheen, the Lagos collection of area rugs from Nourison ingeniously entwines the most inviting aspects of classic and contemporary.

100% POLYESTER | POWER LOOMED | TRADITIONAL DESIGN
NOURISON.COM/LAGOS

AVAILABLE SIZES

2 ft. 3 in. x 7 ft. 6 in. Runner	0.69m x 2.29m Runner
3 ft. x 5 ft.	0.91m x 1.52m
5 ft. Round	1.52m Round
5 ft. 3 in. x 7 ft. 6 in.	1.60m x 2.29m
7 ft. 10 in. x 9 ft. 10 in.	2.39m x 3.00m
8 ft. 3 in. x 11 ft. 6 in.	2.51m x 3.51m
9 ft. 10 in. x 13 ft. 2 in.	3.00m x 4.01m



LAG04 NATURAL

LAG04 SKY



LAG04 BLUE



LAGOS



LAG04 CREAM



LAG04 NATURAL

LUSTROUS WEAVE

COLLECTION



LUW01 IVORY/BLUE

LUW02 BLUE/IVORY



LUSTROUS WEAVE

Muted colors, an erased pattern and delicate sheen lend a subtle elegance and the classic design makes it an easy focal point for any room in your home.

65% LUXCELLE™ | 35% POLYESTER | POWER LOOMED | CONTEMPORARY DESIGN

NOURISON.COM/LUSTROUS-WEAVE

AVAILABLE SIZES

2 ft. 2 in. x 7 ft. 6 in. Runner	0.66m x 2.29m
3 ft. 10 in. x 5 ft. 10 in.	1.17m x 1.78m
5 ft. 3 in. x 7 ft. 9 in.	1.60m x 2.36m
7 ft. 10 in. x 10 ft. 2 in.	2.39m x 3.10m
8 ft. 10 in. x 11 ft. 10 in.	2.69m x 3.61m
10 ft. x 13 ft. 4 in.	3.05m x 4.06m



LUW02 GREY/BEIGE



LUW02 IVORY/BEIGE



LW02 GREY/BRICK



LW04 BLUE/GREY



L U S T R O U S W E A V E



LW03 BLUE



LW03 BLUE/CLOSE UP

LW02 GREY/BRICK

LUXE SHAG

COLLECTION



LXS02 GREY/IVORY

This collection features sleek solid greys and neutral tones as well as traditional Moroccan lattice designs, with plush 2-inch flokati shag pile for comfort that never goes out of style.

100% POLYESTER | POWER LOOMED | CONTEMPORARY DESIGN

NOURISON.COM/LUXE-SHAG

AVAILABLE SIZES

2 ft. 2 in. x 3 ft. 9 in.	0.66m x 1.14m
2 ft. 2 in. x 7 ft. 6 in. Runner	0.66m x 2.29m
4 ft. x 6 ft.	1.22m x 1.83m
5 ft. x 7 ft.	1.52m x 2.13m
8 ft. 2 in. x 10 ft.	2.49m x 3.05m
9 ft. x 12 ft.	2.74m x 3.66m



LXS01 CHARCOAL



LXS02 GREY/IVORY



LXS01 IVORY

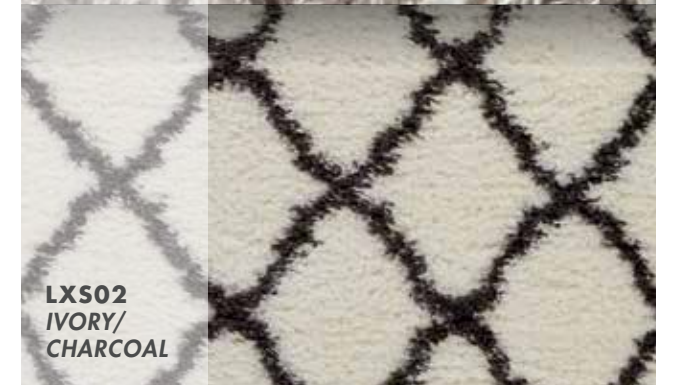

LXS02 IVORY/CHARCOAL



LXS01 LIGHT GREY



LXS02 GREY/IVORY

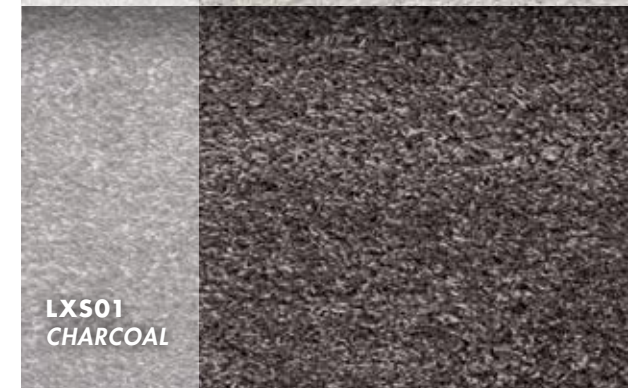

LXS01 CHARCOAL



LXS02 CHARCOAL/BEIGE

MARANA

COLLECTION



Dense loop pile construction from 100% wool, Marana is woven to impart subtle beauty, even in high-traffic areas of the home.

100% WOOL | HAND WOVEN | CONTEMPORARY DESIGN

NOURISON.COM/MARANA

AVAILABLE SIZES

2 ft. 3 in. x 8 ft. Runner	0.69m x 2.44m Runner
3 ft. 9 in. x 5 ft. 9 in.	1.14m x 1.75m
5 ft. x 7 ft. 6 in.	1.52m x 2.29m
6 ft. 6 in. x 9 ft. 6 in.	1.98m x 2.90m
8 ft. x 10 ft. 6 in.	2.44m x 3.20m



MAXELL

COLLECTION



This exceptional collection of area rugs features an inviting assortment of contemporary and classic themes expressed in an array of arresting neutral color palettes.

100% POLYESTER | POWER LOOMED | CONTEMPORARY DESIGN
NOURISON.COM/MAXELL

AVAILABLE SIZES

2 ft. 2 in. x 7 ft. 6 in.	0.66m x 2.29m
3 ft. 10 in. x 5 ft. 10 in.	1.17m x 1.78m
5 ft. 3 in. x 7 ft. 3 in.	1.60m x 2.21m
7 ft. 10 in. x 10 ft. 6 in.	2.39m x 3.20m
9 ft. 3 in. x 12 ft. 9 in.	2.82m x 3.89m

MAE14 IVORY/RED



MAE15 MULTICOLOR



MAXELL



MAE16 IVORY/BLUE



MAE17 IVORY/TEAL

MAE06 FLINT



MAE12 IVORY/GREY



MAE11 GREY



MAE09 CHARCOAL



MAXELL

MAXELL



MAE13 IVORY/TEAL

MAE13 IVORY/GREY

MAE07 IVORY/GREY

MAE01 IVORY/GREY

MAE04 BEIGE



MAE04 GREY



MAE10 IVORY/BLUE



MAE10 IVORY/CHARCOAL



MAXELL

MAXELL



MAE05 MOCHA

MAE05 GRAPHITE

MAE03 MULTICOLOR

MAE02 CHARCOAL

NOMAD

COLLECTION



NMD03 IVORY/PINK

Irregular diamond designs on dramatic abrash fields will bring a sense of global inspiration and energy to any room in your home.

100% POLYPROPYLENE | POWER LOOMED | TRANSITIONAL DESIGN
NOURISON.COM/NOMAD

AVAILABLE SIZES

2 ft. 2 in. x 4 ft.	0.66m x 1.22m
2 ft. 2 in. x 6 ft. Runner	0.66m x 1.83m
2 ft. 3 in. x 8 ft. Runner	0.69m x 2.44m
3 ft. 11 in. x 6 ft.	1.19m x 1.83m
5 ft. 3 in. x 7 ft. 9 in.	1.60m x 2.36m
6 ft. 7 in. x 9 ft. 6 in.	2.01m x 2.90m
7 ft. 10 in. x 10 ft. 6 in.	2.39m x 3.20m
8 ft. 10 in. x 12 ft.	2.69m x 3.66m

NMD01 RED MULTICOLOR

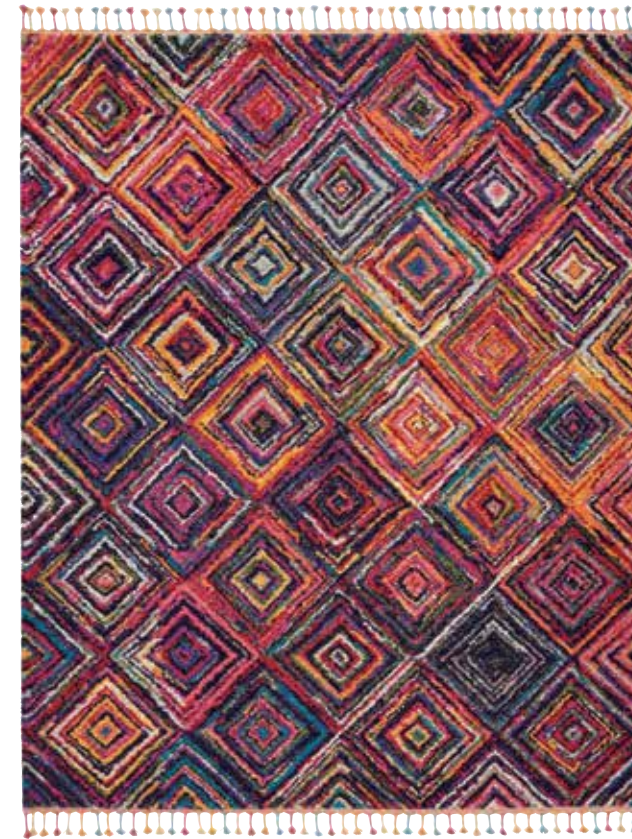

NMD03 IVORY/PINK



NOMAD



NMD06 IVORY MULTICOLOR



NMD02 IVORY MULTICOLOR



NMD04 AQUA

NMD04 CREAM/GREY



N O M A D



NMD04 AQUA

NMD05 NAVY

NMD05 GREY

NOURISON 2020

COLLECTION



NR201 NAVY

This ultra-posh and plush collection of area rugs is as alluring to the eye as it is irresistible to the touch.

A SPECIAL BLEND OF CORN FIBER AND POLYESTER | SPACE DYED | LOOM WOVEN
TRADITIONAL DESIGN

NOURISON.COM/NOURISON-2020

AVAILABLE SIZES	2 ft. x 3 ft.	0.61m x 0.91m	5 ft. 3 in. x 7 ft. 5 in.	0.60m x 2.26m
	2 ft. 3 in. x 8 ft. Runner	0.69m x 2.44m	6 ft. 6 in. x 9 ft. 5 in.	1.98m x 2.87m
	2 ft. 3 in. x 11 ft. Runner	0.69m x 3.35m	7 ft. 5 in. Round	2.26m Round
	2 ft. 6 in. x 4 ft. 2 in.	0.76m x 1.27m	8 ft. x 10 ft. 6 in.	2.44m x 3.20m
	4 ft. x 6 ft.	1.22m x 1.83m	9 ft. 2 in. x 12 ft. 5 in.	2.79m x 3.78m
	5 ft. Round	1.52m Round	12 ft. x 15 ft.	3.66m x 4.57m

NR201 STEEL



NR201 IVORY



NOURISON 2020

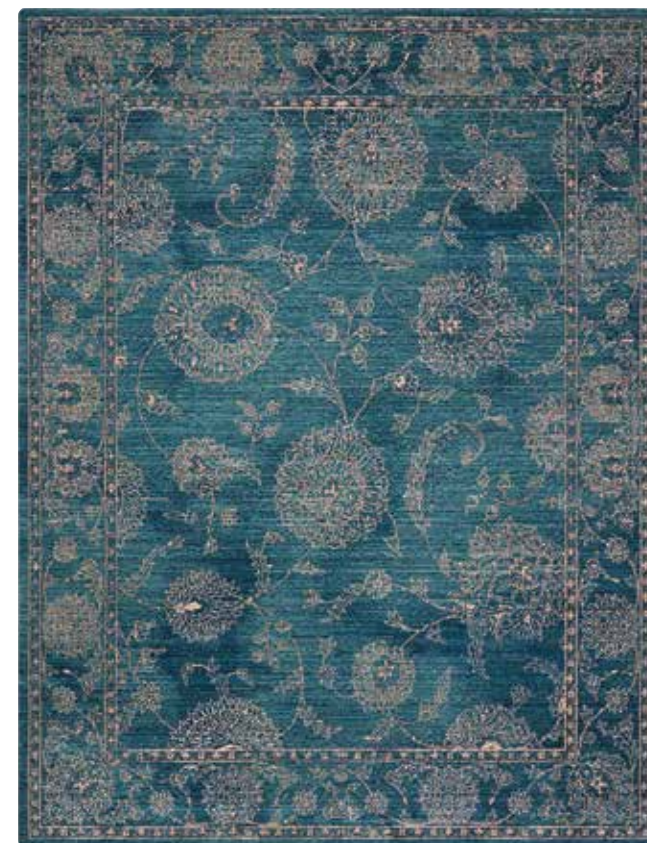

NR202 TEAL



NR202 CHARCOAL

NR207 MARINE



NR204 BRICK



NR205 TERRACOTTA



NR203 MULTICOLOR



NOURISON 2020

NOURISON 2020



NR204 TEAL

NR204 NIGHTFALL

NR206 TEAL

NR206 MIDNIGHT

OSLO SHAG

COLLECTION



OSLO2 DENIM BLUE

Look that brings contemporary and ancient styles together, this rug is at home in any decor setting.

100% POLYPROPYLENE | POWER LOOMED | CONTEMPORARY DESIGN

NOURISON.COM/OSLO-SHAG

AVAILABLE SIZES

4 ft. x 6 ft.	1.22m x 1.83m
5 ft. 3 in. x 7 ft. 9 in.	1.60m x 2.36m
7 ft. 10 in. x 10 ft. 6 in.	2.39m x 3.20m
9 ft. x 12 ft.	2.74m x 3.66m

OSLO2 DENIM BLUE



OSLO2 GREY/IVORY



OSLO SHAG



OSLO2 IVORY/GREY



OSLO3 IVORY/BLUE



OSL03 IVORY/BLUE



OSL01 IVORY/GREY



OSL01 SILVER/GREY

OSLO SHAG



OSL01 SILVER/GREY

RIO VISTA

COLLECTION



DST01 IVORY/ORANGE

The Rio Vista Collection of area rugs from Nourison celebrates India's Dhurrie design, which is loved for its chic simplicity, flat weave, and natural gradations of tone and pattern.

82% WOOL | 10% COTTON | 8% POLYESTER | REVERSIBLE HAND WOVEN
 FLAT WEAVE | CONTEMPORARY DESIGN

NOURISON.COM/RIO-VISTA

AVAILABLE SIZES

2 ft. 3 in. x 8 ft. Runner	0.69m x 2.44m
4 ft. x 6 ft. 6 in.	1.22m x 1.98m
5 ft. x 7 ft. 6 in.	1.52m x 2.29m
8 ft. x 10 ft. 6 in.	2.44m x 3.20m

DST01 IVORY/GREEN



DST01 IVORY/NAVY



RIO VISTA



DST01 IVORY SPA



DST01 IVORY/GREY

RUSTIC TEXTURES

COLLECTION



RUS02 BEIGE/GREY

A mix of earthen tones, combined together with beautiful hi-low textures, bring a rustic sensibility to any decor.

POLYPROPYLENE | POLYESTER | POWER LOOMED | CONTEMPORARY DESIGN

NOURISON.COM/RUSTIC-TEXTURES

AVAILABLE SIZES

2 ft. 2 in. x 7 ft. 6 in. Runner	0.66m x 2.29m
3 ft. 11 in. x 5 ft. 11 in.	1.19m x 1.80m
5 ft. 3 in. x 7 ft. 3 in.	1.60m x 2.21m
7 ft. 10 in. x 10 ft. 6 in.	2.39m x 3.20m
9 ft. 3 in. x 12 ft. 9 in.	2.82m x 3.89m

RUS01 GREY/BEIGE



RUS01 IVORY/SILVER



RUSTIC TEXTURES



RUS02 BEIGE/GREY



RUS02 BLUE/IVORY



RUS03 BEIGE



RUS04 BEIGE/GREY



RUSTIC TEXTURES



RUS05 BEIGE/GREY



RUS05 GREY

RUS06 BEIGE/GREY



RUS06 GREY/BEIGE



RUS07 IVORY/GREY/BLUE



RUS08 GREY/BLUE



R U S T I C T E X T U R E S

R U S T I C T E X T U R E S



RUS06 IVORY/BLUE

RUS07 GREY/BEIGE

RUS09 IVORY/LIGHT BLUE

RUS10 IVORY/BLUE

SILKY TEXTURES

COLLECTION



SLY07 IVORY/BEIGE

The allure is in the sleek, soft pile, featuring a silky sheen that brings fashionable flair to match any décor in your favorite room.

50% VISCOSE | 50% POLYESTER | POWER LOOMED | CONTEMPORARY DESIGN

NOURISON.COM/SILKY-TEXTURES

AVAILABLE SIZES

2 ft. 2 in. x 7 ft. 6 in. Runner	0.66m x 2.29m Runner
3 ft. 11 in. x 5 ft. 11 in.	1.19m x 1.80m
5 ft. 3 in. x 7 ft. 3 in.	1.60m x 2.21m
7 ft. 10 in. x 10 ft. 6 in.	2.39m x 3.20m
9 ft. 3 in. x 12 ft. 9 in.	2.82m x 3.89m

SLY07 IVORY/BEIGE



SLY05 BLUE/GREY



SILKY TEXTURES



SLY01 IVORY/GREY



SLY02 BLUE/CREAM

SLY03 BLUE/IVORY/GREY



SLY03 BROWN/IVORY



SLY08 IVORY/GREY



SLY09 IVORY



SILKY TEXTURES

SILKY TEXTURES



SLY04 BLUE/IVORY/GREY

SLY01 IVORY/BLUE

SLY06 IVORY/GREY

SLY06 IVORY/GREY/CLOSE UP

SOMERSET

COLLECTION



ST90 LIGHT GREEN

Sophisticated color and incomparable texture define this unique collection of high-fashion accent and area rugs.

50% POLYESTER | 50% ACRYLIC | POWER LOOMED
 TRANSITIONAL/CONTEMPORARY DESIGN
NOURISON.COM/SOMERSET

AVAILABLE
 SIZES

2 ft. x 2 ft. 9 in.	0.61m x 0.84m
2 ft. x 5 ft. 9 in. Runner	0.61m x 1.75m Runner
2 ft. 3 in. x 8 ft. Runner	0.69m x 2.44m Runner
3 ft. 6 in. x 5 ft. 6 in.	1.07m x 1.68m
5 ft. 6 in. Round	1.68m Round
5 ft. 3 in. x 7 ft. 5 in.	1.60m x 2.26m
7 ft. 9 in. x 10 ft. 10 in.	2.36m x 3.30m
9 ft. 6 in. x 13 ft. * Select design	2.90m x 3.96m

ST91 TEAL MULTICOLOR



ST790 BRICK



SOMERSET



ST757 NAVY



ST757 LATTE

ST745 GREY



ST745 BLUE

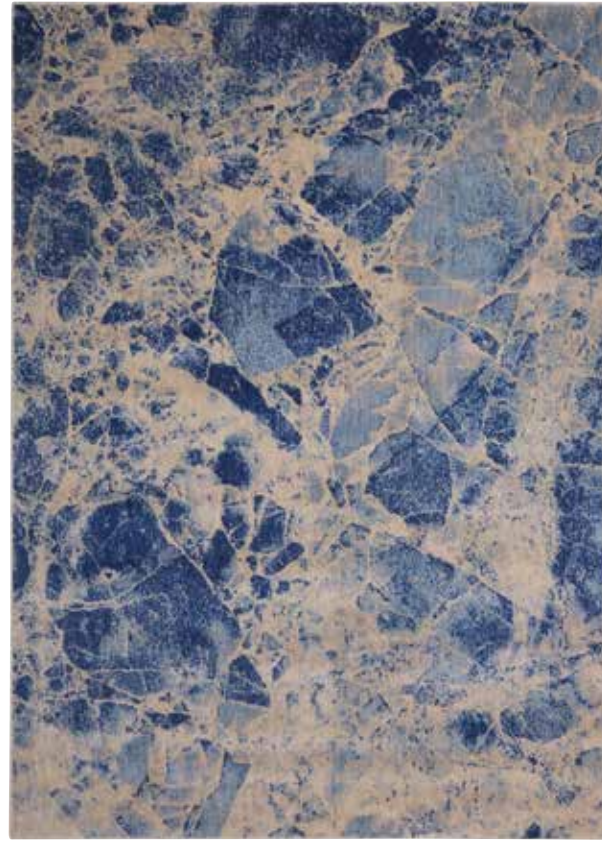

ST22 MULTICOLOR



ST80 MULTICOLOR



S O M E R S E T

S O M E R S E T

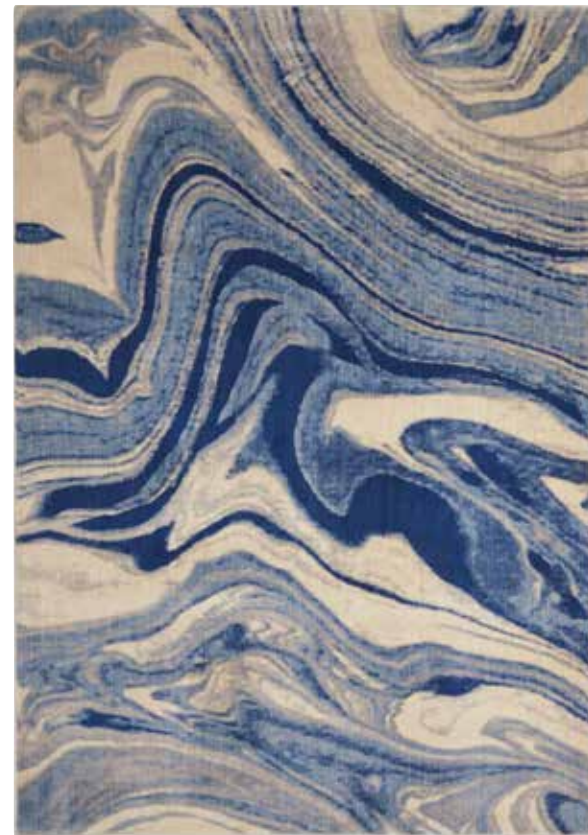
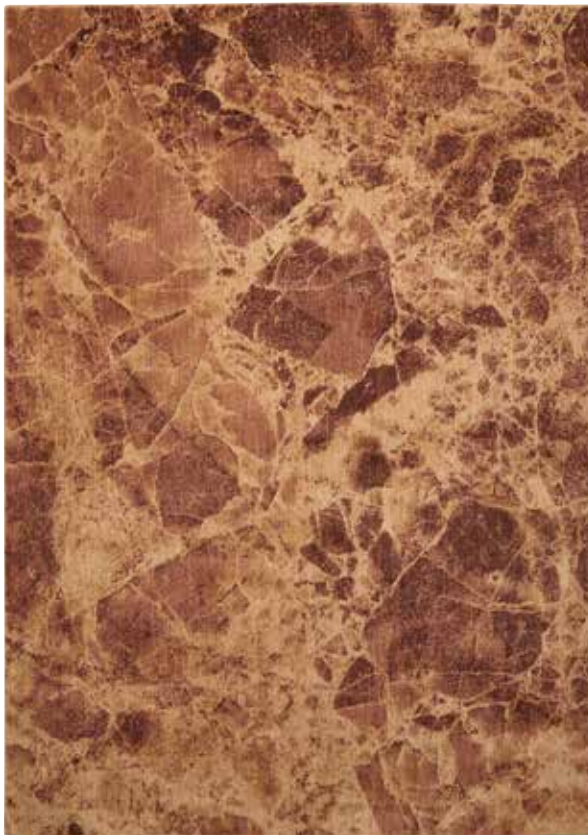

ST745 LATTE

ST749 LIGHT BLUE

ST81 MULTICOLOR

ST81 IVORY/BLUE

ST02 SILVER



ST02 IVORY/BLUE



ST02 IVORY



ST82 BEIGE



S O M E R S E T

S O M E R S E T



ST02 CHARCOAL

ST02 LIGHT BLUE

ST02 NAVY

ST764 DENIM



ST18 IVORY/BLUE

ST18 BEIGE



S O M E R S E T



ST64 MULTICOLOR

ST83 MULTICOLOR

ST18 IVORY/BLUE



ST74 LATTE

ST74 LATTE



ST74 FLAME



S O M E R S E T



ST74 SILVER/BLUE



ST74 MULTICOLOR

SYMMETRY

COLLECTION



SMM10 GREY/BLUE

SMM10 GREY/BLUE

SMM02 GREY/BEIGE



SYMMETRY

With its eye-catching abstracts and complex weave, each style features a distinctive color palette ranging from sophisticated neutrals to bold contrasts.

100% POLYESTER | HAND TUFTED | CONTEMPORARY DESIGN

NOURISON.COM/SYMMETRY

AVAILABLE SIZES

3 ft. 9 in. x 5 ft. 9 in.	1.14m x 1.75m
5 ft. 3 in. x 7 ft. 9 in.	1.60m x 2.36m
7 ft. 9 in. x 9 ft. 9 in.	2.36m x 2.97m
8 ft. 6 in. x 11 ft. 6 in.	2.59m x 3.51m



SMM02 NAVY/BLUE



SMM02 BEIGE/RED



SMM07 LIGHT BLUE/IVORY



SMM05 GREY/YELLOW

SMM08 BLUE/BEIGE



SMM07 LIGHT BLUE/IVORY

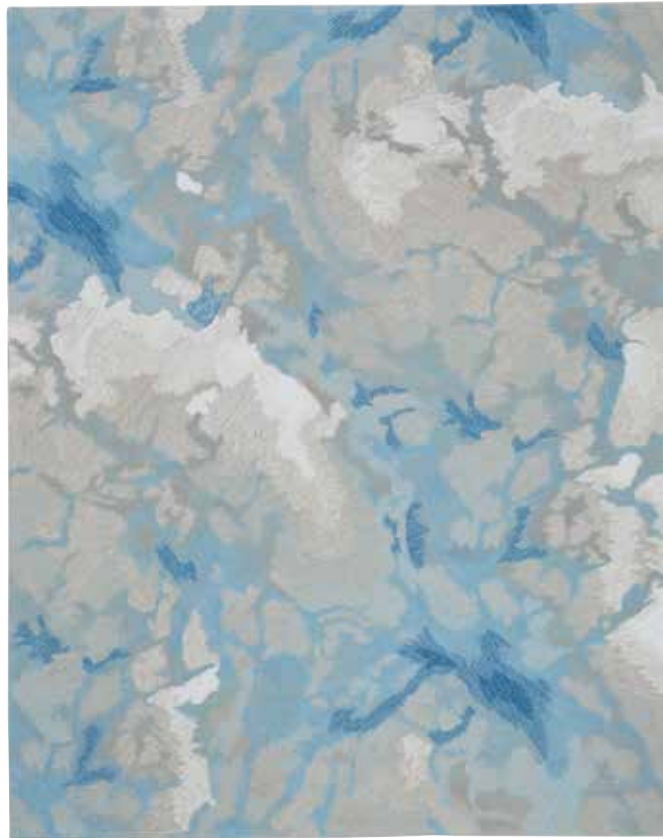

SMM04 IVORY/BEIGE



SMM04 BLUE/GREY



S Y M M E T R Y

S Y M M E T R Y



SMM05 GREY/YELLOW



SMM05 AQUA/BLE



SMM03 IVORY/TAUPE/CLOSE UP



SMM03 IVORY/TAUPE



SMM01 BLUE/IVORY



SMM06 IVORY/GREY



S Y M M E T R Y



SMM09 NAVY

SMM09 NAVY/CLOSE UP

SMM06 IVORY/GREY

VIBRANT

COLLECTION



VIB08 IVORY

The collection features especially brilliant palettes and an alluring array of transitional and bordered designs ranging from Moroccan to tribal to bohemian.

100% WOOL | HAND TUFTED | CONTEMPORARY DESIGN

NOURISON.COM/VIBRANT

AVAILABLE
SIZES

2 ft. 3 in. x 7 ft. 6 in. Runner	0.69m x 2.29m
4 ft. x 6 ft.	1.22m x 1.83m
5 ft. x 7 ft. 6 in.	1.52m x 2.29m
8 ft. x 10 ft. 6 in.	2.44m x 3.20m

VIB08 IVORY



VIB08 TEAL



VIBRANT



VIB09 TEAL



VIB09 NAVY



VIB02 MULTICOLOR

VIB01 IVORY



VIB02 MULTICOLOR



VIBRANT



VIB06 IVORY



VIB07 LIGHT MULTICOLOR

WESTON

COLLECTION



Thick, soft, and luxurious, the Weston Collection brings you an irresistible combination of pleasure and practicality in a modern area rug. These area rugs are richly colorful, stylish, and designed for effortless chic.

78% BAMBOO-EXTRUDED SILK-LIKE FIBER | 22% JUTE | HAND TUFTED
CONTEMPORARY DESIGN

NOURISON.COM/WESTON

AVAILABLE SIZES

2 ft. 3 in. x 7 ft. 6 in. Runner	0.69m x 2.29m Runner
3 ft. 9 in. x 5 ft. 9 in.	1.14m x 1.75m
5 ft. 3 in. x 7 ft. 5 in.	1.60m x 2.26m
8 ft. x 10 ft. 6 in.	2.44m x 3.20m
9 ft. 6 in. x 13 ft.	2.90m x 3.96m



RUG SIZES

N		Amore	Ankara Global	Celestial	Contour	Deco Mod	Denmark Shag	Fantasy	Fusion	Interlock	Jazmine	Jewel	Karma	Lagos	Lustrous Weave	Luxe Shag	Marana	Maxell
		SCATTER & ACCENTS	2 ft x 3 ft							•								
2 ft x 4 ft			•													•		
3 ft x 4 ft								•										
3 ft x 5 ft														•				
RECTANGLE AREA RUGS	4 ft x 6 ft/ 4 ft x 7 ft	•	•	•	•	•	•	•	•	•		•	•		•	•	•	•
	5 ft x 7 ft			•		•			•				•			•		•
	5 ft x 8 ft	•	•		•		•	•		•	•	•		•	•		•	
	6 ft x 8 ft																	
	7 ft x 9 ft/ 7 ft x 10 ft				•												•	
	8 ft x 10 ft										•	•		•	•	•		
	8 ft x 11 ft/ 8 ft x 12 ft	•	•	•	•	•	•	•	•	•			•	•			•	•
	9 ft x 12 ft		•				•				•	•			•	•		
RUNNERS	9 ft x 13 ft												•					•
	6 ft Runner		•															
	8 ft Runner		•			•		•	•	•	•	•	•	•	•	•	•	•
	10 ft Runner										•							
SHAPES	11 ft Runner																	
	4 ft/5 ft Round		•											•				
	6 ft Round		•															
OVERSIZED	8 ft Round																	
	10 ft x 13 ft					•		•						•	•			
	12 ft x 15 ft																	

All sizes approximate. Check individual collections in the catalog for exact sizing.

CUSTOM RUGS

Nomad	Nourison 2020	Oslo Shag	Rio Vista	Rustic Textures	Silky Textures	Somerset	Symmetry	Vibrant	Weston
	•					•			
•									
	•								
•	•	•	•	•	•	•	•	•	•
				•	•				
•	•	•	•			•	•	•	•
•	•								
•	•	•	•	•	•	•	•	•	•
	•								
	•								
						•			
									•
	•								

Nourison offers a variety of custom services for area rugs and broadloom carpet. Our talented design team will work with you to create a unique rug, or you can choose from our extensive library of colors and textures. Nourison can weave your rug from 100% wool, silk, or a combination of both. Various construction techniques are available, including hand knotted and loom woven. Available rug dimensions range from small runners and rounds to oversized mansion rugs, ensuring your dream rug will fit your space perfectly.

For more information, please speak to an authorized Nourison dealer or visit nourison.com/custom

RUG INFORMATION

TYPES OF RUGS

HAND KNOTTED

Hand knotting is the most labor-intensive of rug constructions. In the hands of master weavers, this technique can produce works of art unparalleled in detail and beauty. In a knotted rug, tiny threads are tied onto the warp, creating the pattern or design. The weft threads anchor and align the rows of knots. When the knots are later cut, they stand away from the warp/weft backing to create the velvety pile of the finished piece. The density of the pile is determined by how tightly the knots are packed together. There are a variety of actual knot styles, among which are Persian, Turkish, and Tibetan knots.

In Tibet, native weavers developed a distinctive method long ago of weaving woven on a vertical loom. A Tibetan knot is made when a metal rod is inserted into to the cotton foundation (warp and weft threads) during the knotting process. The two warp threads are at different positions around the weaving rod, and the threads are knotted form left to right.

When the row of knotting is completed, the knots are cut off the metal rod. This creates a surface texture in the pile with the signature horizontal striations that identify “Tibetan weave” to connoisseurs all world over. The most common Tibetan knotted rugs are in 60, 80, or 100 knots per square inch. The higher the knot count, the thinner the carpet. This type of weaving is indicative of tribal and modern designs.

HAND TUFTED

Hand-tufted rugs and hand-hooked rugs are produced with a tufting gun. Working much like an oversized sewing needle, the gun pushes and pulls threads of yarn through a scrim — a pre-woven grid foundation. With a hooked rug, the loops of yarn are left intact to form a characteristically “knobby” pile. In a tufted rug, the tops of loops are sheared to expose the thread ends for a softer and plusher pile.

HAND WOVEN

A flat-weave rug is constructed without a pile. Here, colored weft yarns are woven through the warps to create the pattern. There are numerous varieties of flat weaves: kilims, dhurries, and soumaks, to name a few.

A split-weave kilim is constructed when colored weft yarns are woven through the warps to create the pattern and the thread is pulled through the warp only as far as the pattern and color dictate. Then the thread

is turned back on itself to go the direction in which it came, finishing the same side on which it started. Different colored threads meet but do not join, creating the design.

Nourison’s patented Nourmak technique uses a warp-wrapping process, in which a weft thread is drawn over two to four warps, then back under half of them, repeatedly. The technique produces a herringbone-like effect across the back of the rug. The face of the rug is knotted to replicate worn, antique Persian rug where there is no pile. These rugs also have a hidden weft inserted after every other row.

LOOM WOVEN

Nourison’s loom-woven rugs are made on state-of-the-art looms, which have been customized to weave exceptional quality products with a feel and suppleness that rivals handmade rugs. These loom-woven pieces are then hand washed and hand finished, utilizing time-honored techniques, to accentuate the beauty of each individual rug. Loom-woven rugs from Nourison have the texture, look, and feel of a high-quality handmade piece without the high cost normally associated with handmade rugs.

POWERLOOM

Early powerlooms enabled rug makers to produce floor coverings at a much faster rate than anything woven by hand. Though these early machine made rugs were by no means as detailed as those done by an artisan’s hands, they brought affordability and accessibility to a much larger market. Since the initial development of the powerloom, manufacturers have strived to re-create the look of a fine handmade carpet with varying degrees of success. When purchasing a powerloomed rug, remember, it’s not just about price!

Most important is that your rug is constructed of quality materials, like wool, natural fibers, or lasting synthetics dense enough to ensure—not only that the product lasts—but that it wears beautifully. Hand finishing or carving, featured in many Nourison powerloomed rugs, are sure signs of quality. A finely powerloomed rug is superior in detail and durability to one that is poorly handmade. Nourison’s powerloomed rugs are woven on state-of-the-art Wilton looms, known for their ability to produce incredibly intricate designs and superiorly blended colors. These electronically-driven looms also produce two rugs simultaneously, which are then cut apart, known as face-to-face weaving.

FIBER CONTENT EXPLAINED

ACRYLIC
Synthetic fiber with soft texture and excellent color retention.

BAMBOO-EXTRUDED SILK-LIKE FIBERS
Fibers created by processing bamboo into a soft, silky thread similar to rayon, with antibacterial qualities as well as excellent strength and color retention.

COTTON
Natural fibers created from cotton plants, featuring soft texture and used to create strong threads with excellent color retention.

JUTE
Soft, shiny vegetable fiber spun into course threads.

LEATHER
Tanned animal hide, typically cowhide.

LUREX
Synthetic yarn with a metallic appearance.

LUXCELLE™
A proprietary viscose fiber made from cellulose and purified cotton. Nourison developed the fiber specifically for use as a carpet yarn with superior strength, a fabulous silk-like sheen, and excellent color retention.

NEW ZEALAND WOOL
Generally considered the top quality of wool.

POLYACRYLIC
Synthetic, strong plastic-like fiber.

POLYESTER
Synthetic fiber with excellent durability and color retention.

POLYPROPYLENE
Synthetic, wool like appearance, very strong, excellent color retention.

RAYON
Synthetic fiber with a silk-like feel and excellent color retention.

SILK
Protein fiber, shimmering, strong soft to the touch.

SISAL
Fiber created using sisal plant, often used in ropes as well as woven rugs and mats.

VISCOSE
Synthetic Rayon-like fiber with a structure similar to cotton, created by treating cellulose extracted from plants such as soy, bamboo, and sugar cane.

WOOL
Natural hair harvested from the coats of sheep or goats through sheering. Coarse texture with excellent durability and color retention.

STYLE INFORMATION

TRADITIONAL

Traditional designs are modern-day representations of time-honored European and Asian patterns. In some cases, a traditional rug’s design may be a pattern that has been used for generations.

Traditional rugs are normally considered formal, but they can also be used in casual living spaces.

Traditional rugs normally contain specific elements like floral and other intricate patterns, borders and central medallions.

TRANSITIONAL

This style is a blending of traditional and contemporary styles. Quite often, the blend provides the elegance and timelessness of a traditional pattern with a little less formality.

For example, a transitional rug may feature a classic floral pattern but not a border, or, the rug’s design may feature a border and an intricate pattern but with little color contrast between the two elements.

CONTEMPORARY

Contemporary rug designs are generally characterized by stark contrasts, bold uses of color, and geometric or free-form style elements. They are normally architectural and modern in their look. Contemporary rugs can also feature retro patterns.

Typically these designs are inspired by art deco and arts and crafts periods.

AMORE	Contemporary	1 - 6	LUXE SHAG	Contemporary	57 - 58
ANKARA GLOBAL	Traditional	7 - 12	MARANA	Contemporary	59 - 60
CELESTIAL	Contemporary	13 - 18	MAXELL	Contemporary	61 - 66
CONTOUR	Contemporary	19 - 22	NOMAD	Transitional	67 - 70
DECO MOD	Transitional	23 - 24	NOURISON 2020	Transitional	71 - 74
DENMARK SHAG	Contemporary	25 - 26	OSLO SHAG	Contemporary	75 - 78
FANTASY	Contemporary	27 - 30	RIO VISTA	Contemporary	79 - 80
FUSION	Transitional	31 - 34	RUSTIC TEXTURES	Contemporary	81 - 86
INTERLOCK	Contemporary	35 - 36	SILKY TEXTURES	Contemporary	87 - 90
JAZMINE	Traditional	37 - 40	SOMERSET	Transitional	91 - 100
JEWEL	Traditional	41 - 44	SYMMETRY	Contemporary	101 - 108
KARMA	Transitional	45 - 48	VIBRANT	Contemporary	109 - 112
LAGOS	Traditional	49 - 52	WESTON	Contemporary	113 - 114
LUSTROUS WEAVE	Contemporary	53 - 56			

CLEANING & CARE

BY STAIN, FIBER & BLENDS

NOURISON.COM/RUG-CARE

STAIN	SUGGESTED CLEANING AND CARE
Acids	Detergent or white vinegar
Alcoholic beverages	Detergent, white vinegar, or cleaning fluid
Ammonia or Alkali	Detergent or white vinegar
Ball-point pen ink	Methylated spirits or turpentine
Beer	Detergent or white vinegar
Bleach	Detergent or white vinegar
Blood	Detergent, white vinegar, or starch paste
Burning cigarette	Brush off with a hard edge
Butter	Cleaning fluid
Candy	Detergent, white vinegar, or scrape & vacuum
Cellulose paint	Acetone
Chewing gum	Detergent, white vinegar, or cleaning fluid
Chocolate	Detergent, white vinegar, or cleaning fluid
Coffee	Glycerin
Cosmetics	Detergent, white vinegar, or cleaning fluid
Crayon	Detergent, white vinegar, or cleaning fluid
Egg	Detergent or white vinegar
Excrement (human)	Detergent or white vinegar
Excrement (pet)	Call a reputable cleaner
Fat and Oil	Blot with tissue, then use cleaning fluid
Fruit and juices	Detergent or white vinegar
Furniture polish	Detergent, white vinegar, or cleaning fluid
Glue	Alcohol
Grass	Methylated spirits
Gravy	Detergent, white vinegar, or cleaning fluid
Grease	Use cleaning fluid, or scrape and vacuum
Household cement	Detergent, white vinegar, or cleaning fluid*
Ice cream	Detergent, white vinegar, or cleaning fluid*
Ink	Water only
Iodine	Alcohol
Jam	Lukewarm water
Lipstick	Detergent, white vinegar, or cleaning fluid*
Medicine	Call a reputable cleaner
Metal polish	Detergent, white vinegar, or cleaning fluid*
Mildew	Call a reputable cleaner
Milk	Detergent, white vinegar, or cleaning fluid*
Mud	Detergent or white vinegar
Mustard	Detergent or white vinegar
Nail polish	Polish remover*
Oils	Cleaning fluid
Paint	Detergent, white vinegar, or cleaning fluid*

Perfume	Detergent, white vinegar or cleaning fluid*
Permanent ink	Call a reputable cleaner
Rust	Call a reputable cleaner
Salad dressing	Detergent, white vinegar, or cleaning fluid*
Sauces	Detergent, white vinegar, or cleaning fluid*
Shoe polish	Detergent, white vinegar, cleaning fluid, or scrape and vacuum
Soot	Vacuum, then use cleaning fluid
Tar	Cleaning fluid
Tea	Detergent or white vinegar
Urine (human)	Detergent or white vinegar
Urine (pet)	Call a reputable cleaner
Vomit	Detergent, white vinegar, or cleaning fluid
Wax	Cleaning fluid, or scrape and vacuum
Wine	Detergent, white vinegar, or cleaning fluid

FIBER	SUGGESTED CLEANING AND CARE
New Zealand Wool Wool Rayon Cotton Nylon Faux Silk Acrylic Polyacrylic Modacrylic Polyester Polypropylene Shag Excel (Faux Silk/Cotton)	<ul style="list-style-type: none"> • Vacuum regularly. • Pile shedding is a normal characteristic of quality area rugs. • Avoid use of beater-bar type vacuum as they may cause yarns to pull or snag. • If this happens, avoid pulling yarn knots out of surface pile. • Clean spills immediately by blotting with a clean sponge or cloth. • Always use a professional cleaning service. Consumer self-cleaning methods are discouraged. • Rug padding is recommended.
Hair on Hide Leather Cowhide Suede Leather	<ul style="list-style-type: none"> • Natural skin rugs are not recommended for high-traffic areas. • Vacuum regularly on the lowest setting. Vacuums with beater bars are not recommended. • Clean spills immediately by wiping smoothly in the direction of the hair with a damp (but not wet) cloth, using mild soap and water. • Always use a professional cleaning service. Consumer self-cleaning methods are discouraged. • Rug Padding is recommended.
Jute Sisal	<ul style="list-style-type: none"> • Do not steam clean or wet shampoo your jute rug. Plant fibers are highly absorbent, so they are subject to some shrinking and puckering when exposed to liquids or excessive dampness. • Always use a professional cleaning service. Consumer self-cleaning methods are discouraged. • Rug Padding is recommended.
Viscose Luxcelle™ Bamboo-extruded Silk-like Fibers	<ul style="list-style-type: none"> • Vacuum regularly. Vacuums with beater bars are not recommended. • Avoid pulling yarn knots out of surface pile. • Always use a professional cleaning service. Consumer self-cleaning methods are discouraged. Carpet can easily stain and yellow with improper cleaning chemicals. • For spills, blot the affected area with white paper towels or a clean white terry cloth towel. Moisture will weaken the fiber, and rubbing could then cause breaking or damage. • After blotting stains, groom by combing the face of the rug in the direction of the pile with a soft brush. The pile may look flatter and more reflective afterward. • Once dry, re-brush the fiber to regain original texture. • Rug padding is recommended.

*If recommended procedure is not effective, call a reputable cleaner, particularly for complex stains. Don't wait for annual cleaning, since it may be too late by then to remove the stain.

RUG PAD

10 YEAR GUARANTEE

GUARANTEED TO RETAIN ITS NON-SLIP PROPERTIES WITH PROPER CARE

FOR SAFETY

Rug pads hold rugs in place. A rug pad can help prevent bunching, which can lead to tripping; and rug shift, which can lead to slipping. Even when a rug seems "secured" by furniture or on carpet, a rug pad adds an extra layer of protections against mishaps.

FOR DURABILITY

Rug pads protect the rug's weave, which can be worn by the constant pulling and tugging of foot traffic and vacuuming. A rug pad extends the life of the rug, and protects your investment.

FOR COMFORT & AESTHETICS

Rug pads provide extra padding, increasing comfort, insulation, and sound proofing in the home. A rug pad also provides a buffer zone for dirt and dust, keeping them off of your hard surfaces, and making them easier to vacuum away.

IT IS IMPORTANT TO CHOOSE THE RIGHT TYPE OF RUG PAD FOR YOUR FLOORING

Hard surface rug pads can be used on hardwood, stone, tile or vinyl.



Advanced protection and cushioning for hard surfaces. Provides superior, ultra-thick cushioning to prevent pile crush & extend rug life. Rug pads hold rugs in place, helping prevent bunching & slipping. Open weave allows ventilation for vacuuming & moisture evaporation.

FEATURES

POLYESTER WITH HIGH-GRADE VINYL
WILL NOT STAIN OR DISCOLOR FLOOR
HANDWASH

FIRM GRIP

AVAILABLE SIZES

1 ft. 10 in. x 7 ft. 6 in.
1 ft. 8 in. x 9 ft. 6 in.
1 ft. 10 in. x 11 ft. 6 in.
2 ft. 6 in. x 4 ft. 2 in.
3 ft. 4 in. x 5 ft.
4 ft. 8 in. x 7 ft. 6 in.
5 ft. 8 in. x 8 ft. 6 in.
7 ft. 6 in. round
7 ft. 6 in. x 9 ft. 6 in.
7 ft. 6 in. x 10 ft. 6 in.
8 ft. 6 in. x 11 ft. 6 in.
9 ft. 6 in. x 13 ft. 6 in.
11 ft. 6 in. x 14 ft. 6 in.



Premier protection and cushioning. Provides the ultimate in cushioning and insulation. The needle-punched fabric and textured waffle-backing provides improved gripping power. Use with the needle-punched fabric down while on carpet, and with the textured waffle-backing when on wood, tile, and other hard surfaces. Superior thickness is ideal for tile and uneven surfaces & reduces puckering under furniture.

FEATURES

100% POST INDUSTRIAL RECYCLED SYNTHETIC FIBERS
GREEN LABEL PLUS CERTIFIED
MAY BE USED OUTDOORS

RUG LOC

AVAILABLE SIZES

2 ft. x 8 ft.
2 ft. x 10 ft.
2 ft. x 12 ft.
3 ft. x 5 ft.
5 ft. round
5 ft. x 8 ft.
6 ft. x 9 ft.
7 ft. 6 in Round
8 ft. x 10 ft.
8 ft. x 11 ft.
9 ft. x 12 ft.
10 ft. x 14 ft.
12 ft. x 15 ft.

LOCATIONS

SHOWROOMS & HEADQUARTERS

NOURISON.COM

NOURISON INDUSTRIES, INC., US HEADQUARTERS

5 Sampson St., Saddle Brook, NJ 07663
(800) 223-1110 | Fax (201) 368-0739

NEW YORK SHOWROOM

295 Fifth Ave. Suite 518, 5th Floor New York, NY 10016
(212) 545-1030

ATLANTA SHOWROOM

Atlanta Merchandise Mart | 240 Peachtree St. N.W., Space 1L1, 2, Atlanta, GA 30303
(404) 584-7255

LAS VEGAS SHOWROOM

World Market Center, Building C | 455 S. Grand Central Pkwy., Suite C112, Las Vegas, NV 89106
(702) 454-2600

HIGHPOINT SHOWROOM

International Home Furnishings Center (IHFC) | 210 E. Commerce Ave., InterHall IH101 High Point, NC 27260
(336) 841-6900

NOURISON EUROPE

Freilagerstrasse 39, 8047 Zurich, Switzerland
(+41) 044 401 45 46/47 | Fax (+41) 044 401 45 48

Photos and images in this catalog are for reference only; actual colors and textures may vary.
Rugs shown are of specific size; design details may vary with size changes.

©NOURISON 2020

NOURISON.COM

